

SALES DRAWING SALES DRAWING

SALES DRAWING SALES DRAWING

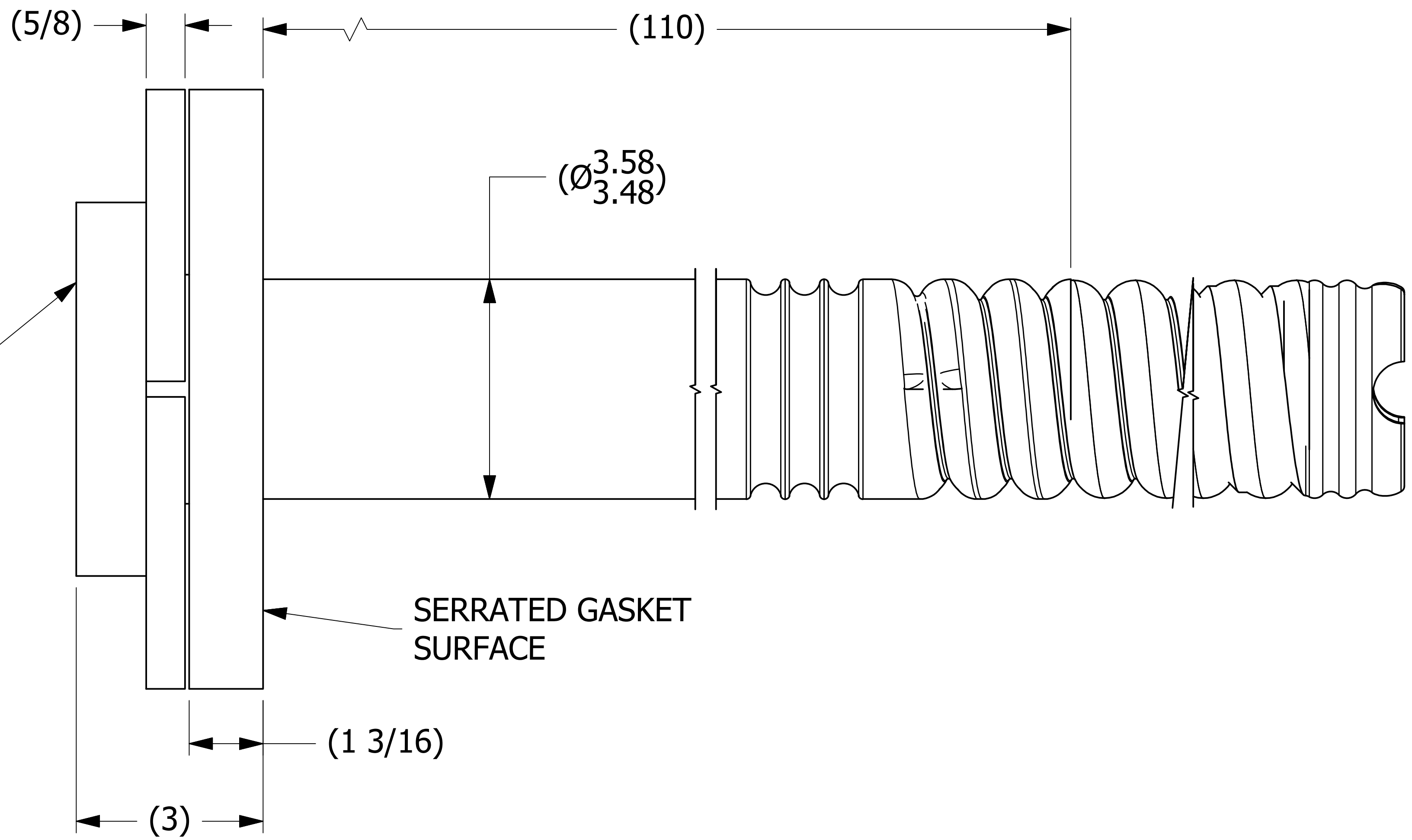
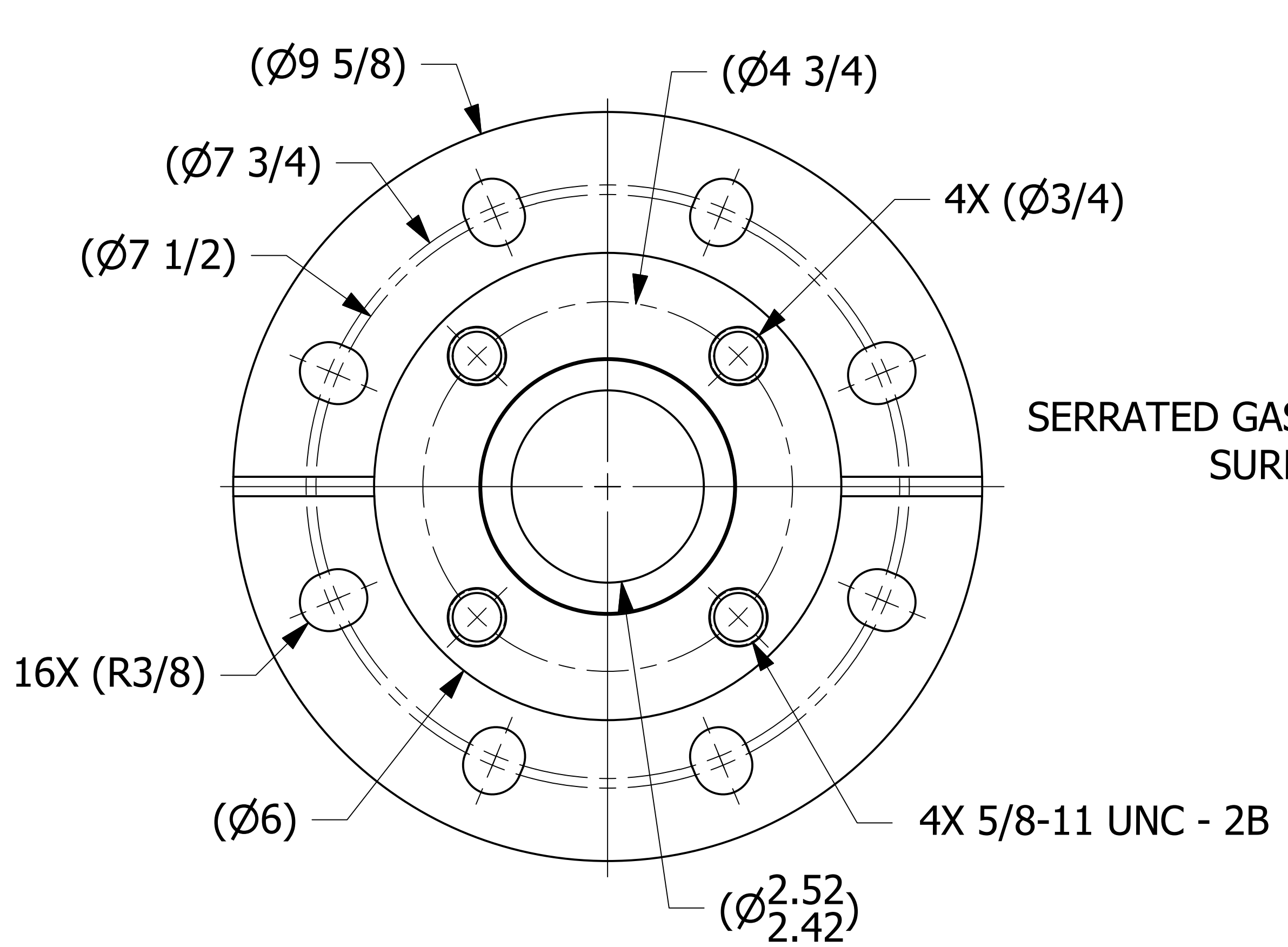

NOTES:

1. FOR FINISH TUBE LENGTHS OF 121" TO 127 1/2"
2. PATENT NO. US 8,894,102 B2.
3. FOR NON-FLAMMABLE SERVICE ONLY.
4. AAR APPROVAL NUMBER IS E-162104.

REV	BY	DATE	DESCRIPTION
E	JG	5-30-18	Q-2.14 WAS QAP5A-1; AAR WAS E-099032; ADDED PATENT NUMBER; UPDATED HS3TB113, NOTES, VIEWS; ADDED LAL20T & HS3HSTKA TO BOM
D	JG	4-29-14	UPDATED TITLEBLOCK, NOTES, AND DIMS
C	JJK	6-1-12	BROKE DOWN SUB-ASSEMBLIES INTO INDIVIDUAL PARTS AND UPDATED DRAWING TO CURRENT STANDARDS
B	TAJ	2-22-12	CHANGED MACHINING PROCESS FOR PART (SEE NOTES) REPLACED HS42DTSPS4ETFE WITH HS4DTSPS4
A	SMA	7-27-11	NEW DRAWING ADDED TO SYSTEM

<small>UNLESS OTHERWISE SPECIFIED DIMENSIONAL TOLERANCES</small> FRACTIONAL: ±1/16 X.XX: ±.03 X.XXX: ±.015 ANGULAR: ±1° DEBURR ALL SHARP EDGES. ALL MACHINED SURFACES TO HAVE A 125 RMS FINISH UNLESS NOTED OTHERWISE. <small>THIRD ANGLE PROJECTION</small>	DRAWN BY:	VD
	CHECKED BY:	CHL
	PROTOTYPE BY:	VD
	PROTOTYPE DATE:	2/15/2011
	APPROVED FOR PRODUCTION BY:	CHL
	PRODUCTION DATE:	7/27/2011

SALCO PRODUCTS, INC.

EDUCATION TUBE 4" X 2" X 3 1/2"

MATERIAL: **SEE DWG**

PROJECT #: **110216** SHEET #: **1 OF 1** SCALE: **1:1**

DRAWING #: **D30247** PART #: **HS42DT110**

THIS PRINT, PROPERTY OF SALCO PRODUCTS INC. CONTAINS PROPRIETARY INFORMATION AND MUST NOT BE COPIED, REPRODUCED, OR USED DETRIMENTALLY TO OUR INTEREST.